

92×92×38mm Series



使用材料/
ハウジング: プラスチック (UL:V-0)
インペラー: プラスチック (UL:V-0)
軸受構造/ボールベアリング
保護方法/電流制限
使用温度範囲/−10℃~70℃
質量/216g

MATERIAL/
HOUSING: Plastic (UL:V-0)
IMPELLER: Plastic (UL:V-0)
BEARING/ Ball Bearings
PROTECTION/ Current limit
OPERATING TEMP/ −10℃~70℃
MASS/ 216g

外形図 External Dimensions

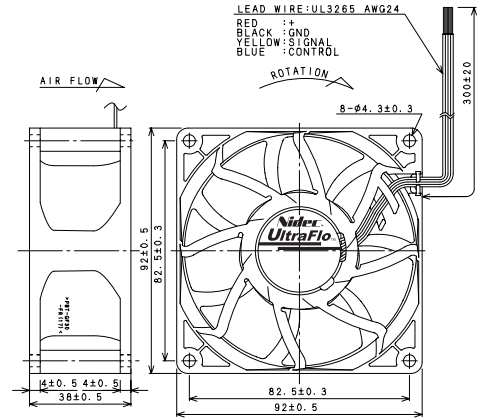

取り付け穴参考寸法 Panel Out - Cuts

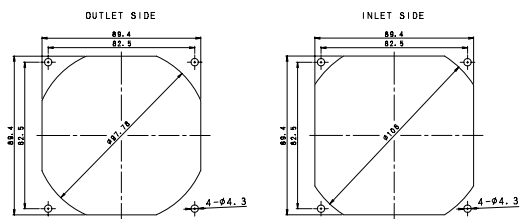

特性 Major Characteristic Parameters

●フィードバック制御有り Feedback Control Design

Model	Rated Voltage	Operating Voltage range	Rated Current	Maximum Air Flow		Maximum Static Pressure		Rated Input Power	Sound Level	Rated Speed
	V	V	A	m ³ /min	CFM	Pa	inchH ₂ O	W	dB (A)	min ⁻¹
V92E12BLA7-0*	12	7.0~13.8	0.36	2.32	81.7	140	0.56	4.36	44.0	4000
V92E12BMA7-0*	12	7.0~13.8	0.62	2.86	101	180	0.72	7.39	50.0	5000
V92E12BHA7-0*	12	7.0~13.8	1.32	3.80	134	285	1.15	15.84	56.5	6500
V92E12BGA7-0*	12	7.0~13.8	2.05	4.39	155	345	1.39	24.55	60.0	7500
V92E12BUA7-0*	12	7.0~13.8	2.97	5.05	178	460	1.85	35.64	64.0	8500

●フィードバック制御無し Without Feedback Control Design

Model	Rated Voltage	Operating Voltage range	Rated Current	Maximum Air Flow		Maximum Static Pressure		Rated Input Power	Sound Level	Rated Speed
	V	V	A	m ³ /min	CFM	Pa	inchH ₂ O	W	dB (A)	min ⁻¹
V92E12BLA7-5*	12	7.0~13.8	0.36	2.32	81.7	115	0.46	4.36	44.0	4000
V92E12BMA7-5*	12	7.0~13.8	0.62	2.86	101	170	0.68	7.39	50.0	5000
V92E12BHA7-5*	12	7.0~13.8	1.32	3.80	134	255	1.03	15.84	56.5	6500
V92E12BGA7-5*	12	7.0~13.8	2.05	4.39	155	325	1.31	24.55	60.0	7500
V92E12BUA7-5*	12	7.0~13.8	2.97	5.05	178	400	1.61	35.64	64.0	8500

(注) データは定格電圧での代表特性です。
Sound Levelは吸込側表面から1mにて測定した値です。
電源PWMは保証外とします。
電源の電圧リップルは定格電圧の±5%以下とします。
上記以外の定格電圧については、個別にお問い合わせ下さい。

(Note) The data shows typical value at rated voltage.
Sound Level is measured at the distance of one(1) meter from the axis of fan intake.
Insurance does not apply to power supply PWM.
The range of voltage ripples for power supply is ±5%.
Contact us on any rated voltage not listed above.

特性グラフ P-Q Curve

